

Engineering Data
AC Servo Motors CHM

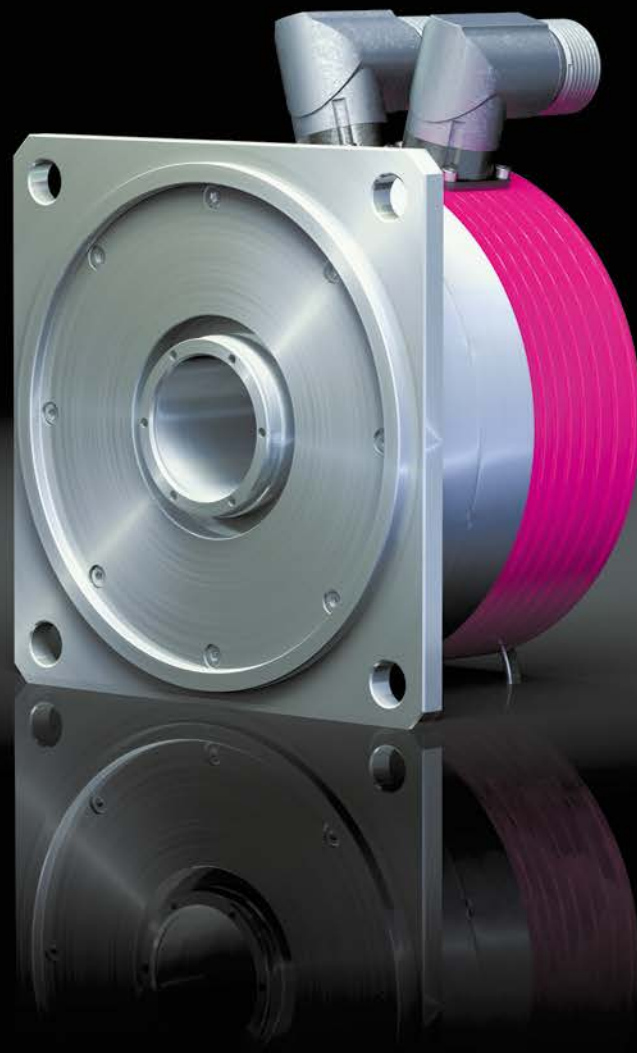

Harmonic
Drive AG



QUICKLINK
www.harmonicdrive.de/1080

...just move it!

Contents

1.	General	03
1.1	Description of Safety Alert Symbols	04
1.2	Disclaimer and Copyright	04
2.	Safety and Installation Instructions	05
2.1	Hazards	05
2.2	Intended Purpose	06
2.3	Non Intended Purpose	07
2.4	Declaration of Conformity	07
3.	Technical Description	08
3.1	Product Description	08
3.2	Ordering Code	09
3.3	Technical Data	11
3.3.1	General Technical Data	11
3.3.2	Actuator Data	12
3.3.3	Dimension	14
3.3.4	Output Bearing	16
3.3.5	Motor Feedback Systems	17
3.3.6	Temperature Sensors	20
3.3.7	Electrical Connections	21
4.	Actuator Selection Procedure	24
4.1	Selection Procedure and Calculation Example	24
5.	Installation and Operation	28
5.1	Transport and Storage	28
5.2	Installation	28
5.3	Mechanical Installation	28
5.4	Electrical Installation	29
5.5	Commissioning	30
5.6	Overload Protection	30
5.7	Protection against Corrosion and Penetration of Liquids and Debris	31
5.8	Shutdown and Maintenance	31
6.	Decommissioning and Disposal	33
7.	Glossary	34
7.1	Technical Data	34
7.2	Labelling, Guidelines and Regulations	40
8.	Appendix	41
8.1	Declaration of Conformity	41

1. General

About this documentation

This document contains safety instructions, technical data and operation rules for servo actuators and servo motors of Harmonic Drive AG.

The documentation is aimed at planners, project engineers, commissioning engineers and machine manufacturers, offering support during selection and calculation of the servo actuators, servo motors and accessories.

Rules for storage

Please keep this document for the entire life of the product, up to its disposal. Please hand over the documentation when re-selling the product.

Additional documentation

For the configuration of drive systems using the products of Harmonic Drive AG, you may require additional documents. Documentation is provided for all products offered by Harmonic Drive AG and can be found in pdf format on the website.

www.harmonicdrive.de

Third-party systems

Documentation for parts supplied by third party suppliers, associated with Harmonic Drive® components, is not included in our standard documentation and should be requested directly from the manufacturers.





Before commissioning servo actuators and servo motors from Harmonic Drive AG with servo drives, we advise you to obtain the relevant documents for each device.

Your feedback

Your experiences are important to us. Please send suggestions and comments about the products and documentation to:

Harmonic Drive AG
Marketing and Communications
Hoenbergstraße 14
65555 Limburg / Lahn
Germany
E-Mail: info@harmonicdrive.de

1.1 Description of Safety Alert Symbols

Symbol	Meaning
	Indicates an imminent hazardous situation. If this is not avoided, death or serious injury could occur.
	Indicates a possible hazard. Care should be taken or death or serious injury may result.
	Indicates a possible hazard. Care should be taken or slight or minor injury may result.
	Describes a possibly harmful situation. Care should be taken to avoid damage to the system and surroundings.
	This is not a safety symbol. This symbol indicates important information.
	Warning of a general hazard. The type of hazard is determined by the specific warning text.
	Warning of dangerous electrical voltage and its effects.
	Beware of hot surfaces.
	Beware of suspended loads.
	Precautions when handling electrostatic sensitive components.

1.2 Disclaimer and Copyright

The contents, images and graphics contained in this document are protected by copyright. In addition to the copyright, logos, fonts, company and product names can also be protected by brand law or trademark law. The use of text, extracts or graphics requires the permission of the publisher or rights holder.

We have checked the contents of this document. Since errors cannot be ruled out entirely, we do not accept liability for mistakes which may have occurred. Notification of any mistake or suggestions for improvements will be gratefully received and any necessary correction will be included in subsequent editions.

2. Safety and Installation Instructions

Please take note of the information and instructions in this document. Specially designed models may differ in technical detail. If in doubt, we strongly recommend that you contact the manufacturer, giving the type designation and serial number for clarification.

2.1 Hazards



DANGER

Electric servo actuators and motors have dangerous live and rotating parts. All work during connection, operation, repair and disposal must be carried out by qualified personnel as described in the standards EN50110-1 and IEC 60364! Before starting any work, and especially before opening covers, the actuator must be properly isolated. In addition to the main circuits, the user also has to pay attention to any auxiliary circuits.

Observing the five safety rules:

- Disconnect mains
- Prevent reconnection
- Test for absence of harmful voltages
- Ground and short circuit
- Cover or close off nearby live parts

The measures taken above must only be withdrawn when the work has been completed and the device is fully assembled. Improper handling can cause damage to persons and property. The respective national, local and factory specific regulations must be adhered to.



ATTENTION

The surface temperature of gears, motors and actuators can exceed 55 degrees Celsius. The hot surfaces should not be touched.

ADVICE

Cables must not come into direct contact with hot surfaces.



DANGER

Electric, magnetic and electromagnetic fields are dangerous, in particular for persons with pacemakers, implants or similar. Vulnerable groups must not be in the immediate vicinity of the products themselves.



DANGER

Built-in holding brakes alone are not functional safe. Particularly with unsupported vertical axes, the functional safety and security can only be achieved with additional, external mechanical brakes.



WARNING

The successful and safe operation of gears, servo actuators and motors requires proper transport, storage and assembly as well as correct operation and maintenance.



ADVICE

Use suitable lifting equipment to move and lift gears, servo actuators and motors with a weight > 20 kg.

INFORMATION

Special versions of products may differ in the specification from the standard. Further applicable data from data sheets, catalogues and offers of the special version have to be considered.

2.2 Intended Purpose

The Harmonic Drive® servo actuators and motors are intended for industrial or commercial applications. They comply with the relevant parts of the harmonised EN 60034 standards series.

Typical areas of application are robotics and handling, machine tools, packaging and food machines and similar machines.

The servo actuators and motors may only be operated within the operating ranges and environmental conditions shown in the documentation (altitude, degree of protection, temperature range etc).

Before plant and machinery which have Harmonic Drive® servo actuators and motors built into them are commissioned, the compliance must be established with the Machinery Directive, Low Voltage Directive and EMC guidelines.

Plant and machinery with inverter driven motors must satisfy the protection requirements in the EMC guidelines. It is the responsibility of the installer to ensure that installation is undertaken correctly.

Signal and power lines must be shielded. The EMC instructions from the inverter manufacturer must be observed in order that installation meets the EMC regulations.

2.3 Non Intended Purpose

The use of servo actuators and motors outside the areas of application mentioned above or, inter alia, other than in the operating areas or environmental conditions described in the documentation is considered as non-intended purpose.

ADVICE

Direct operating from the mains supply is not allowed.

The following areas of application are, inter alia, those considered as non-intended purpose:

- Aerospace
- Areas at risk of explosion
- Machines specially constructed or used for a nuclear purpose whose breakdown might lead to the emission of radio-activity
- Vacuum
- Machines for domestic use
- Medical equipment which comes into direct contact with the human body
- Machines or equipment for transporting or lifting people
- Special devices for use in annual markets or leisure parks

2.4 Declaration of Conformity

The Harmonic Drive® servo actuators and motors described in the engineering data comply with the Low Voltage Directive. A copy of the EC conformity declaration is supplied in the appendix.

In accordance with the Machinery Directive, Harmonic Drive® servo actuators and servo motors are electrical equipment for the use within certain voltage limits as covered by the Low Voltage Directive and thus excluded from the scope of the Machinery Directive. Commissioning is prohibited until the final product conforms to the Machinery Directive.

3. Technical Description

3.1 Product Description

High speed and low cogging torque

The CHM Servo Motor is characterised by distributed winding, high resolution measuring systems and a hollow shaft. Available in five sizes, the motors offer maximum torques from 2.8 to 37 Nm at speeds of up to 6,500 rpm.

To adapt to specific applications, the CHM Series offer numerous possible combinations covering the selection of motor feedback systems, brakes and various cable as well as connector options.

By combining the CHM Servo Motors with the specially adapted YukonDrive® Servo Controllers, it is possible to provide a single source supply for a pre-configured drive system tailored to suit your application. Alternatively, the flexible configuration of the actuator ensures compatibility with almost any servo controller on the market.

The integrated hollow shaft can be used to feed through supply lines or services for additional axes, enabling space saving designs with minimal installation dimensions required. Accurate positioning ensures stable machine characteristics, short cycle times and minimum space requirements. With high protection ratings and corrosion resistance, the series is perfectly suited for use in harsh and demanding environmental conditions.

3.2 Ordering Code

Table 9.1

Series	Size	Motor winding	Connector configuration	Motor feedback	Degree of protection	Brake	Special design
CHM	0083A	AM	H L	CDO SDH ¹⁾ MDH ¹⁾	54 65	B	According to customer requirements
	0200A	AR					
	0390A	AU					
	0800A	AX					
	1100A	AX					
Ordering Code							
CHM - 0083A - AM - H - MDH - 54 - B - SP							

¹⁾ The availability of the motor feedback systems SDH and MDH is limited until approximately 2016 due to the availability of some electronic components!

Table 9.2

Motor winding		
Size	Ordering Code	Maximum DC bus voltage
0083A	AM	680 VDC
0200A	AR	
0390A	AU	
0800A	AX	
1100A	AX	

Table 9.3

Connector configuration			
Ordering Code	Motor	Motor feedback	
		SDH MDH	CDO
H	6 pol. (M23)	12 pol. (M23)	17 pol. (M23)
L	8 pol. (M23)		

Table 9.4

Motor feedback		
Ordering Code	Type	Protocol
CDO	Incremental	-
SDH	Single-turn absolute	HIPERFACE®
MDH	Multi-turn absolute	

Table 9.5

Degree of protection	
Ordering Code	Description
54	IP54
65	IP65

Explanation of the technical data can be found in the Glossary.

Combinations

Table 10.1

Size		0083A	0200A	0390A	0800A	1100A
Motor winding	AM	●	-	-	-	-
	AR	-	●	-	-	-
	AU	-	-	●	-	-
	AX	-	-	-	●	●
Connector configuration	H	●	●	●	●	●
	L	●	●	●	●	●
Motor feedback	CDO	●	●	●	●	●
	SDH	●	●	●	●	●
	MDH	●	●	●	●	●
Degree of protection	54	●	●	●	●	●
	65	●	●	●	●	●
Brake	B	●	●	●	●	●

● available ○ on request - not available



3.3 Technical Data

3.3.1 General Technical Data

Table 11.1

Insulation class (EN 60034-1)		F
Insulation resistance (500VDC)	MΩ	100
Insulation voltage (10s)	V _{rms}	2500
Degree of protection (EN 60034-5)		IP54 ... IP65
Ambient operating temperature	°C	0 ... 40
Ambient storage temperature	°C	-20 ... 60
Altitude (a. s. l.)	m	< 1000
Relative humidity (without condensation)	%	20 ... 80
Vibration resistance (DIN IEC 68 Part 2-6, 10 ... 500 Hz)	g	5
Shock resistance (DIN IEC 68 Part 2-27, 18 ms)	g	30
Temperature sensor		1 x KTY 84-130 // 1 x PTC 116-K135-145° C
Shaft tolerances		DIN 42955

The continuous operating characteristics specified in the following refer to a temperature rise of the motor winding of 100 K at an ambient temperature of 40 degrees Celsius. The continuous operating characteristic curve applies to actuators mounted on an aluminium plate with the following dimensions.

Table 11.2

Series	Size Version	Unit	Dimensions
CHM	0083A	[mm]	300 x 300 x 15
	0200A	[mm]	350 x 350 x 18
	0390A	[mm]	400 x 400 x 20
	0800A	[mm]	500 x 500 x 25
	1100A	[mm]	600 x 600 x 30

3.3.2 Actuator Data

Table 12.1

	Symbol [Unit]	CHM-0083A		CHM-0200A		CHM-0390A		CHM-0800A		CHM-1100A	
		IP54	IP65	IP54	IP65	IP54	IP65	IP54	IP65	IP54	IP65
Degree of protection											
Maximum output torque	T_{max} [Nm]	2.9	2.8	6.4	6.4	11.3	11.2	27	27	37	37
Maximum output speed	n_{max} [rpm]	6500		5600		4000		4000		4000	
Continuous stall torque	T_0 [Nm]	0.76	0.70	1.8	1.7	3.9	3.7	8.0	7.9	11.0	11.0
Rated torque	T_N [Nm]	0.6	0.4	1.4	1.1	2.5	1.9	7.0	6.0	10.5	9.6
Rated speed	n_N [rpm]	3000		3000		3000		3000		3000	
Rated power	P_N [W]	190	120	450	350	800	600	2200	1900	3300	3015
Maximum current	I_{max} [A _{rms}]	10		14		16		20		28	
Rated current	I_N [A _{rms}]	2.1	1.7	3.1	2.5	3.6	2.9	4.6	4.2	6.8	6.3
Continuous stall current	I_0 [A _{rms}]	2.5		3.6		5.0		5.2		7.2	
Torque constant (at motor)	k_{TM} [Nm/A _{rms}]	0.30	0.27	0.50	0.48	0.77	0.75	1.5	1.5	1.5	1.5
AC voltage constant (L-L, 20° C, at motor)	k_{EM} [V _{rms} /1000 rpm]	23		37		53		104		104	
Maximum DC bus voltage	U_{DCmax} [V _{DC}]	680		680		680		680		680	
Motor terminal voltage (fundamental wave only)	U_M [V _{rms}]	220 ... 430		220 ... 430		220 ... 430		430		430	
Electrical time constant (20° C)	t_e [ms]	1.4		1.7		2.1		3.4		3.5	
Mechanical time constant (20° C)	t_m [ms]	5.7		5.0		4.5		2.5		2.1	
Resistance (L-L, 20° C)	R_{L-L} [Ω]	5.9		3.7		2.9		3.5		2.4	
Inductance (L-L)	L_{L-L} [mH]	8.0		6.0		6.0		12.0		8.5	
Number of pole pairs	p []	5		6		6		6		6	
Weight without brake	m [kg]	1.3		2.9		4.7		7.3		8.9	
Weight with brake	m [kg]	2.0		4.1		6.8		10.9		12.6	
Hollow shaft diameter	d_h [mm]	21		36		42		46		46	

Moment of Inertia

Table 12.2

	Symbol [Unit]	CHM-0083A	CHM-0200A	CHM-0390A	CHM-0800A	CHM-1100A
Moment of inertia without brake	J [x10 ⁻⁴ kgm ²]	0.94	3.2	8	13.9	17.3
Moment of inertia with brake	J [x10 ⁻⁴ kgm ²]	1.2	4.1	9.9	16.6	18

Technical Data Brake

Table 12.3

	Symbol [Unit]	CHM-0083A	CHM-0200A	CHM-0390A	CHM-0800A	CHM-1100A
Brake voltage	U_{Br} [V _{DC}]	24 ±10%	24 ±10%	24 ±10%	24 ±10%	24 ±10%
Brake holding torque (at output)	T_{Br} [Nm]	1	2	5	5	10
Brake current to open	I_{OBr} [A _{DC}]	0.6	0.9	0.8	0.8	1.0
Brake current to hold (10 V)	I_{HBr} [A _{DC}]	0.3	0.4	0.3	0.3	0.5
Number of brake cycles at $n = 0$ rpm		10000000	10000000	10000000	10000000	10000000
Emergency brake cycles		200	200	200	200	200
Opening time	t_o [ms]	110	110	110	110	110
Closing time	t_c [ms]	70	70	70	70	70

Performance Characteristics

The performance curves shown below are valid for the specified ambient operating temperature if the motor terminal voltage is higher or equal to the values given in the ratings table.

Illustration 13.1 CHM-0083A

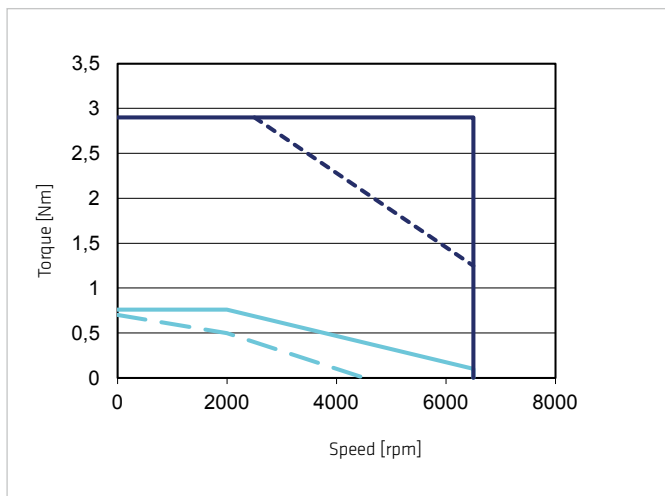

Illustration 13.2 CHM-0200A

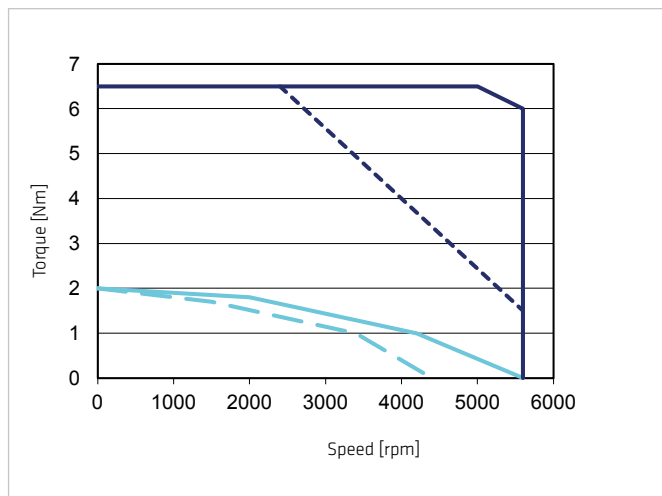

Illustration 13.3 CHM-0390A

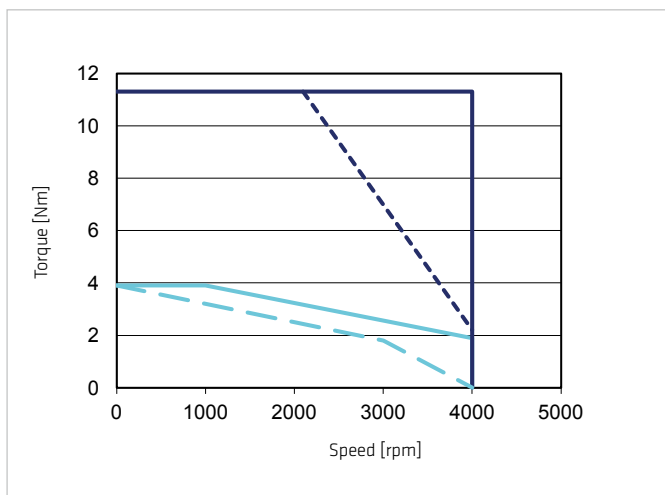

Illustration 13.4 CHM-0800A

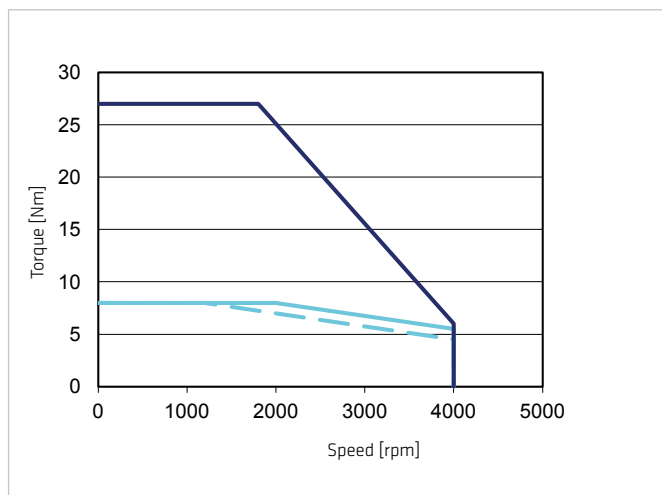
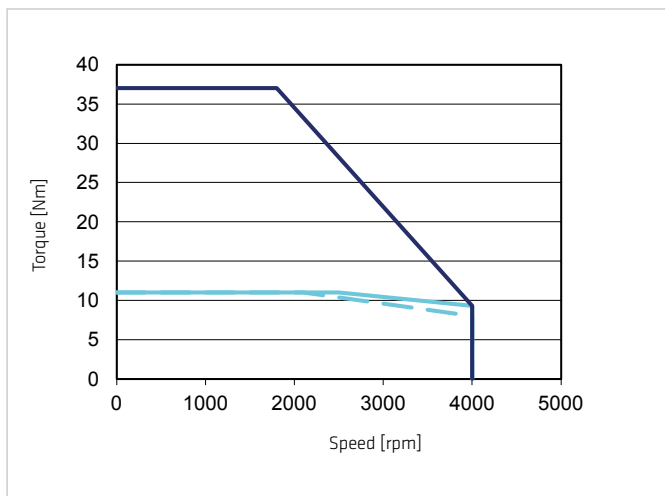

Illustration 13.5 CHM-1100A



Legend

Intermittent duty — $U_M = 430 \text{ VAC}$ - - -
 Continuous duty IP54 — $U_M = 220 \text{ VAC}$ - - -
 Continuous duty IP65 - - -

3.3.3 Dimensions

Detailed 2D drawings and 3D models can be found at the following Quicklink:
QUICKLINK www.harmonicdrive.de/CAD1080

Illustration 14.1 CHM-0083A [mm]

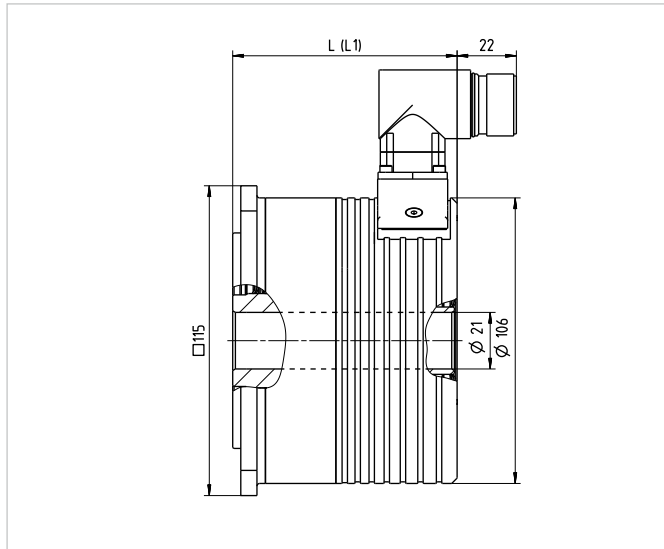

Illustration 14.2 CHM-0200A

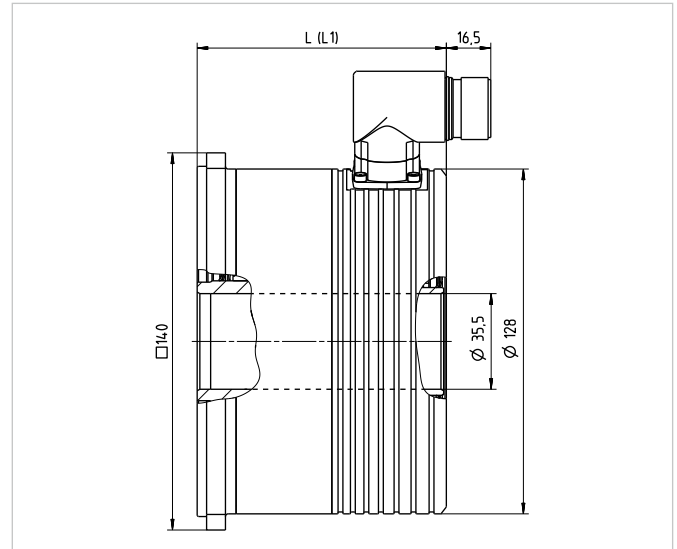

Table 14.3

	Symbol [Unit]	CHM-0083A	CHM-0200A
Motor feedback system		CDO / SDH / MDH	CDO / SDH / MDH
Length (without brake)	L [mm]	83.3	92.5
Length (with brake)	L1 [mm]	103.3	120

Illustration 14.4 CHM-0390A [mm]

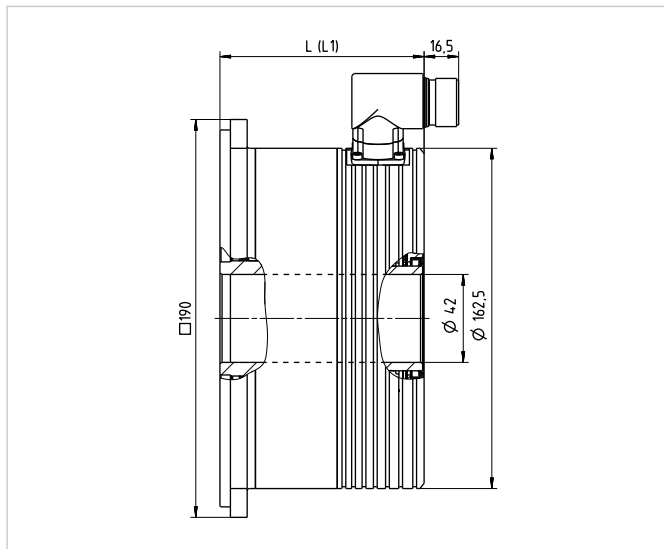

Illustration 14.5 CHM-0800A

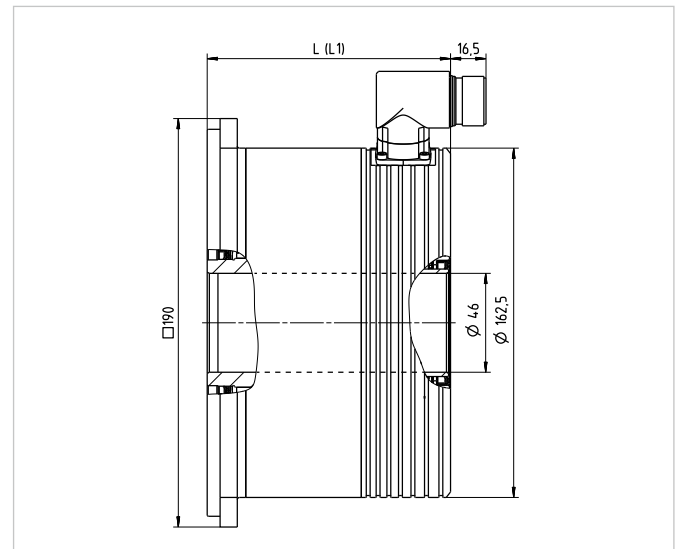

Table 14.6

	Symbol [Unit]	CHM-0390A	CHM-0800A
Motor feedback system		CDO / SDH / MDH	CDO / SDH / MDH
Length (without brake)	L [mm]	97.5	113.2
Length (with brake)	L1 [mm]	116.5	132.5

Illustration 15.1

CHM-1100A [mm]

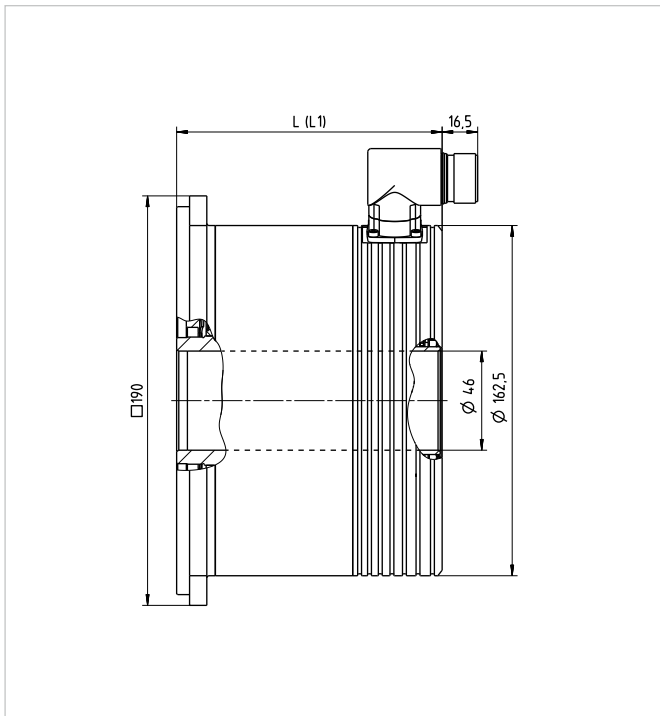
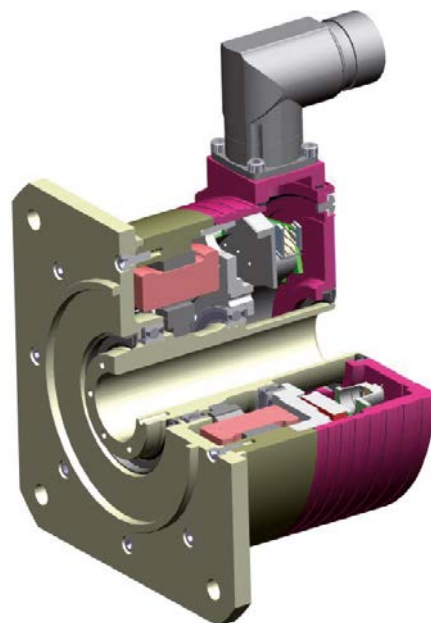

Table 15.2

	Symbol [Unit]	CHM-1100A
Motor feedback system		CDO / SDH / MDH
Length (without brake)	L [mm]	123.2
Length (with brake)	L1 [mm]	144.2



3.3.4 Output Bearing

The AC Servo Motors CHM incorporate a high stiffness output bearing to support output loads. This bearing can withstand high axial and radial forces as well as high tilting moments.

Technical Data

Table 16.1

	Symbol [Unit]	CHM-0083A	CHM-0200A	CHM-0390A	CHM-0800A	CHM-1100A
Bearing type ¹⁾		R	R	R	R	R
Offset bearing to shaft end	R [mm]	31	30	34	50	60
Offset bearing to shaft end	R [mm]	15	17	18	19	19
Dynamic tilting moment	$M_{dyn(max)}$ [Nm]	6.7	9.4	12	23	27
Dynamic axial load ²⁾	$F_{A dyn(max)}$ [N]	180	210	220	280	280
Dynamic radial load ²⁾	$F_{R dyn(max)}$ [N]	220	310	350	450	450

1) R = Ball bearing

2) 10000h bei 3000 rpm

Tolerances according to DIN 42955 N

Table 16.2

	Symbol [Unit]	CHM-0083A	CHM-0200A	CHM-0390A	CHM-0800A	CHM-1100A
Radial eccentricity	[mm]	0.050	0.050	0.060	0.060	0.060
Concentricity	[mm]	0.080	0.100	0.100	0.100	0.100
Axial eccentricity	[mm]	0.080	0.100	0.100	0.100	0.100

3.3.5 Motor Feedback Systems

Design and Operation

For accurate position setting, the servo motor and its control device are fitted with a measuring device (feedback), which determines the current position (e.g. the angle of rotation set for a starting position) of the motor.

This measurement is effected via a rotary encoder, e.g. a resolver, an incremental encoder or an absolute encoder. The position controller compares the signal from this encoder with the pre-set position value. If there is any deviation, then the motor is turned in the direction which represents a shorter path to the set value which leads to the deviation being reduced. The procedure repeats itself until the value lies incrementally or approximately within the tolerance limits. Alternatively, the motor position can also be digitally recorded and compared by computer to a set value.

Servo motors and actuators from Harmonic Drive AG use various motor feedback systems which are used as position transducers to fulfil several requirements.

Commutation

Commutation signals or absolute position values provide the necessary information about the rotor position, in order to guarantee correct commutation.

Actual Speed

The actual speed is obtained in the servo controller using the feedback signal, from the cyclical change in position information.

Actual Position

Incremental encoder

The actual signal value needed for setting the position is formed by adding up the incremental position changes. Where incremental encoders have square wave signals, definition of the edge evaluation can be quadrupled (quad counting). Where incremental encoders have SIN / COS signals, then the definition can be increased by interpolation in the control device.

Absolute encoder

Absolute encoders deliver absolute position information about one (single-turn) or several (multi-turn) rotations. This information can on the one hand provide the rotor position for commutation and on the other hand possibly a reference of travel. Where absolute encoders have additional incremental signals, then typically the absolute position information can be read at power up and the incremental signals then evaluated to determine the rotation and actual position value. Fully digital absolute encoders as motor feedback systems have such a high definition of the absolute value that there is no need for additional incremental signals.

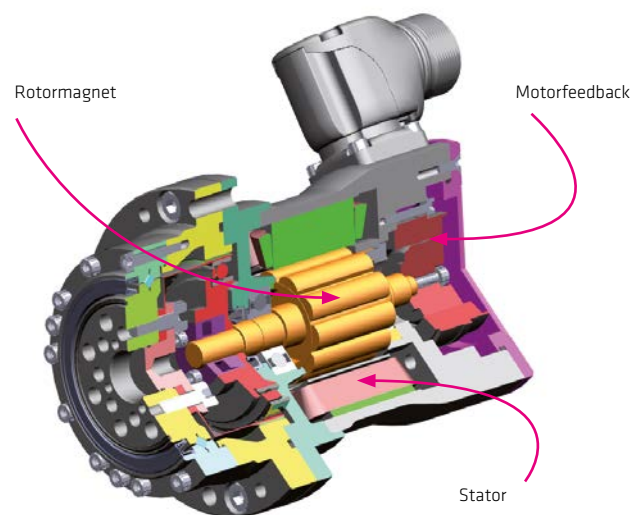

**Incremental motor feedback with SIN / COS signals
reference and commutation signals**

Table 18.1

Ordering Code	Symbol [Unit]	CDO
Manufacturer's designation		CCK
Power supply ¹⁾	U_b [VDC]	$5 \pm 10\%$
Current consumption ¹⁾	I [mA]	150
Incremental signals	u_{pp} [V _{SS}]	$1 + 20\% / - 25\%$
Signal form		sinusoidal
Number of pulses	n_1 [A / B]	1024
Commutation signals	u_{pp} [V _{SS}]	1
Signal form		sinusoidal
Number of pulses	n_2 [C / D]	1
Reference signal	n_3 [R]	1
Accuracy ¹⁾	[arcsec]	± 12
Incremental resolution ²⁾	inc []	262144
	[arcsec]	4.9

¹⁾ Source: Manufacturer

²⁾ For interpolation with 8 bit

Signal wave form

Illustration 18.2

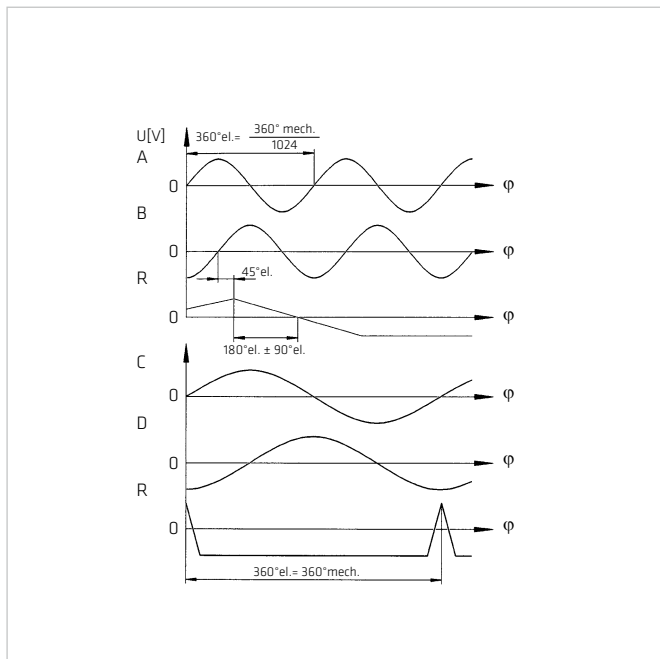

Valid for direction of rotation
- CW at the motor shaft (when viewed from the front face of the motor)

SDH

Single turn absolute motor feedback system with incremental SIN / COS signals and HIPERFACE® data interface

Table 19.1

Ordering Code	Symbol [Unit]	SDH
Manufacturer's designation		SCK
Type identifier ¹⁾		22 _n
Protocol		HIPERFACE®
Power supply ¹⁾	U_b [VDC]	7 ... 12
Current consumption (max.. without Last) ¹⁾	I [mA]	110
Incremental signals	u_{pp} [V _{ss}]	0.8 ... 1.1
Signal form		sinusoidal
Number of pulses	n_1 [SIN / COS]	1024
Absolute position / revolution (motor side) ³⁾		32768
Available memory in EEPROM	[Bytes]	128
Available memory in EEPROM ¹⁾	[arcsec]	±180
Resolution of the absolute value	[arcsec]	39.6
Incremental resolution ²⁾	inc []	262144
	[arcsec]	4.9

¹⁾ Source: Manufacturer

³⁾ increasing position values

²⁾ For interpolation with 8 bit

- for rotation in clockwise direction, looking at the motor shaft

MDH

Multi-turn absolute motor feedback system with incremental SIN / COS signals and HIPERFACE® data interface

Table 19.2

Ordering Code	Symbol [Unit]	MDH
Manufacturer's designation		SCL
Type identifier ¹⁾		27 _n
Protocol		HIPERFACE®
Power supply ¹⁾	U_b [VDC]	7 ... 12
Current consumption (max., without Last) ¹⁾	I [mA]	110
Incremental signals	u_{pp} [V _{ss}]	0.8 ... 1.1
Signal form		sinusoidal
Number of pulses	n_1 [SIN / COS]	1024
Absolute position / revolution (motor side) ³⁾		32768
Number of revolutions		4096
Available memory in EEPROM	[Bytes]	128
Available memory in EEPROM ¹⁾	[arcsec]	±180
Resolution of the absolute value	[arcsec]	39.6
Incremental resolution ²⁾	inc []	262144
	[arcsec]	4.9

¹⁾ Source: Manufacturer

³⁾ increasing position values

²⁾ For interpolation with 8 bit

- for rotation in clockwise direction, looking at the motor shaft

3.3.6 Temperature Sensors

For motor protection at speeds greater than zero, temperature sensors are integrated in the motor windings. For applications with high load where the speed is zero, additional protection (eg $I^2 t$ monitoring) is recommended. When using the KTY 84-130 the values given in the table can be parametrized in the servo controller or an external evaluation unit.

Table 20.1

Sensor type	Parameter	T_{Nat} [°C]
PTC-116-K135-145°	Rated operating temperature	145

PTC thermistors, because of their very high positive temperature coefficient at nominal operating temperature (T_{nat}), are ideally suited for motor winding protection.

Due to their principle, the PTC sensors should only be used to monitor the winding temperature.

Illustration 20.2

Diagram PTC

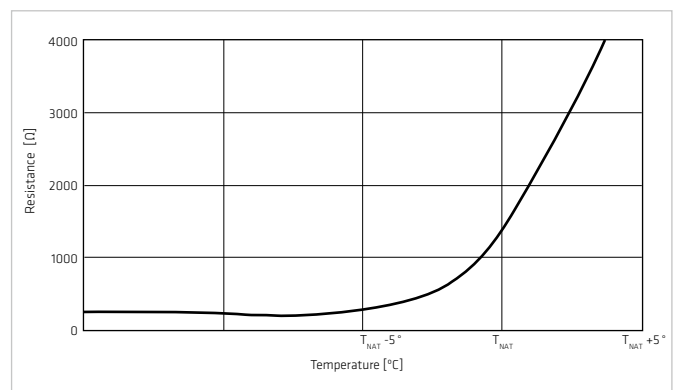

Table 20.3

Sensor type	Parameter	Symbol [Unit]	Warning	Shutdown
KTY 84-130	Temperature	T [°C]	120	140
	Resistance	R [Ω]	$1127 \pm 3\%$	$1262 \pm 3\%$

The KTY sensor is used for temperature measurement and monitoring the motor winding.

Because the KTY sensor provides an analogue temperature measurement, it is also possible to protect the actuator grease from temperature overload.

Temperature sensors used in the CHM Actuator Series meet the requirements for safe separation according to EN50178.

Illustration 20.4

Diagram KTY 84-130

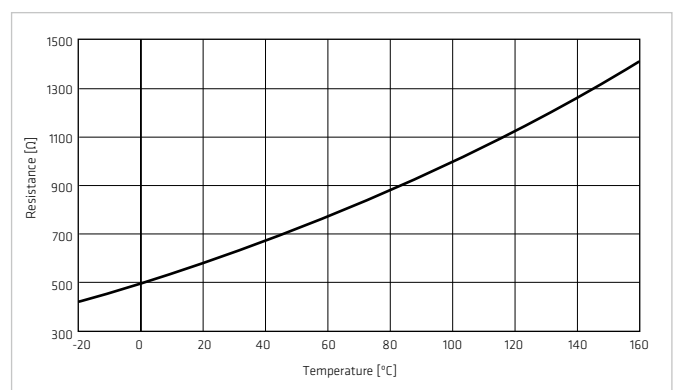

3.3.7 Electrical Connections

CHM-xxxx-H-CDO

Table 21.1

Motor connector	6 / M23 x 1
Cable plug	6 / M23 x 1 / Part no. 301193
External diameter	ca. 26 mm
Length	ca. 60 mm

Illustration 21.2

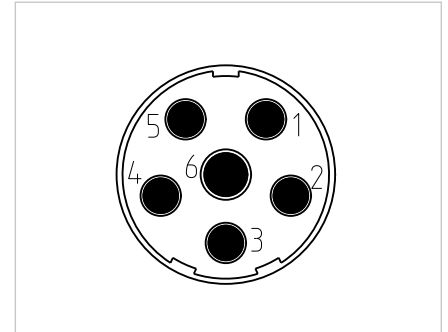

Table 21.3

	CHM					
Connector pin	1	2	3	4	5	6
Motor phase	U	V	PE	BR+	BR-	W

Table 21.4

Encoder connector	17 / M23 x 1
Cable plug	17 / M23 x 1 / Part no. 270199
External diameter	ca. 26 mm
Length	ca. 60 mm

Illustration 21.5

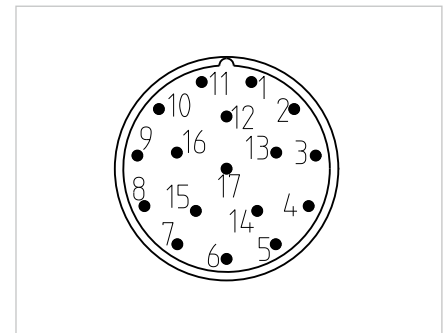

Table 21.6

Connector pin	1	2	3	4	5	6	7 (15)	8	9	10 (16)	11	12	13	14	15 (7)	16 (10)	17
CDO	A+	A-	R+	D-	C+	C-	GND	Temp+ KTY	Temp- KTY	Up	B+	B-	R-	D+	GND Sensor	Up Sensor	Inner shield

Connecting cables SINAMICS S120 with SMC Modul

Table 22.1

Power Connection	
CHM without brake	6FX8002-5CA01-1xx0
CHM with brake	6FX8002-5DA01-1xx0
Motor feedback	
H-CDO	6FX8002-2CA31-1xx0

Connecting cables with flying leads

Table 22.2

Version	Part no.	Length [m]
H-CDO	308853	5
	308854	10
	308855	15
	308856	20
	308857	25

CHM-xxxx-L-SDH / L-MDH

Table 23.1

Motor connector	8 / M23 x 1
Cable plug	8 / M23 x 1 / Part no. 303549
External diameter	ca. 26 mm
Length	ca. 60 mm

Illustration 23.2

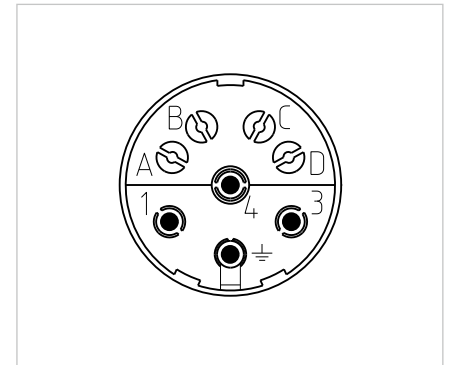

Table 23.3

Connector pin	CHM							
	1	2	3	4	A	B	C	D
Motor phase	U	PE	W	V	BR+	BR-	Temp+ PTC	Temp- PTC

Table 23.4

Encoder connector	12 / M23 x 1
Cable plug	12 / M23 x 1 / Part no. 305068
External diameter	ca. 26 mm
Length	ca. 60 mm

Illustration 23.5

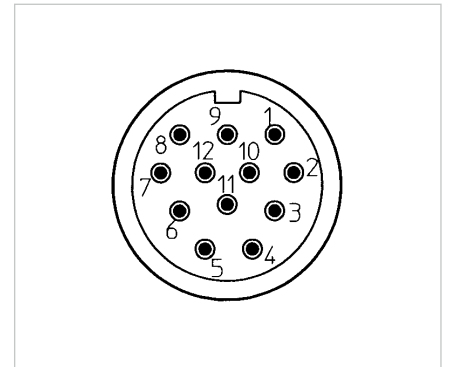

Table 23.6

Connector pin	1	2	3	4	5	6	7	8	9	10	11	12
SDH MDH Signal	Us	GND	SIN	REFSIN	Data+	Data-	COS	REFCOS	Temp+ KTY	Temp- KTY		

Connecting cables for the connection to YukonDrive®

Table 23.7

Version	Part no.	Length [m]
L-SDH L-MDH	314411	3
	314412	5
	314413	10

4. Actuator Selection Procedure

4.1. Selection Procedure and Calculation Example

Flowchart for actuator selection

Equation 24.1

$$T_1 = T_L + \frac{2\pi}{60} \cdot \frac{(J_{out} + J_L) \cdot n_2}{t_1}$$

Equation 24.2

$$T_2 = T_L$$

$$T_3 = T_L \cdot (T_1 - T_L)$$

$$T_{rms} = \sqrt{\frac{T_1^2 \cdot t_1 + T_2^2 \cdot t_2 + T_3^2 \cdot t_3}{t_1 + t_2 + t_3 + t_p}}$$

Equation 24.3

$$n_{av} = \frac{\frac{n_2}{2} \cdot t_1 + n_2 \cdot t_2 + \frac{n_2}{2} \cdot t_3}{t_1 + t_2 + t_3 + t_p}$$

Equation 24.4

$$ED = \frac{t_1 + t_2 + t_3}{t_1 + t_2 + t_3 + t_p} \cdot 100 \%$$

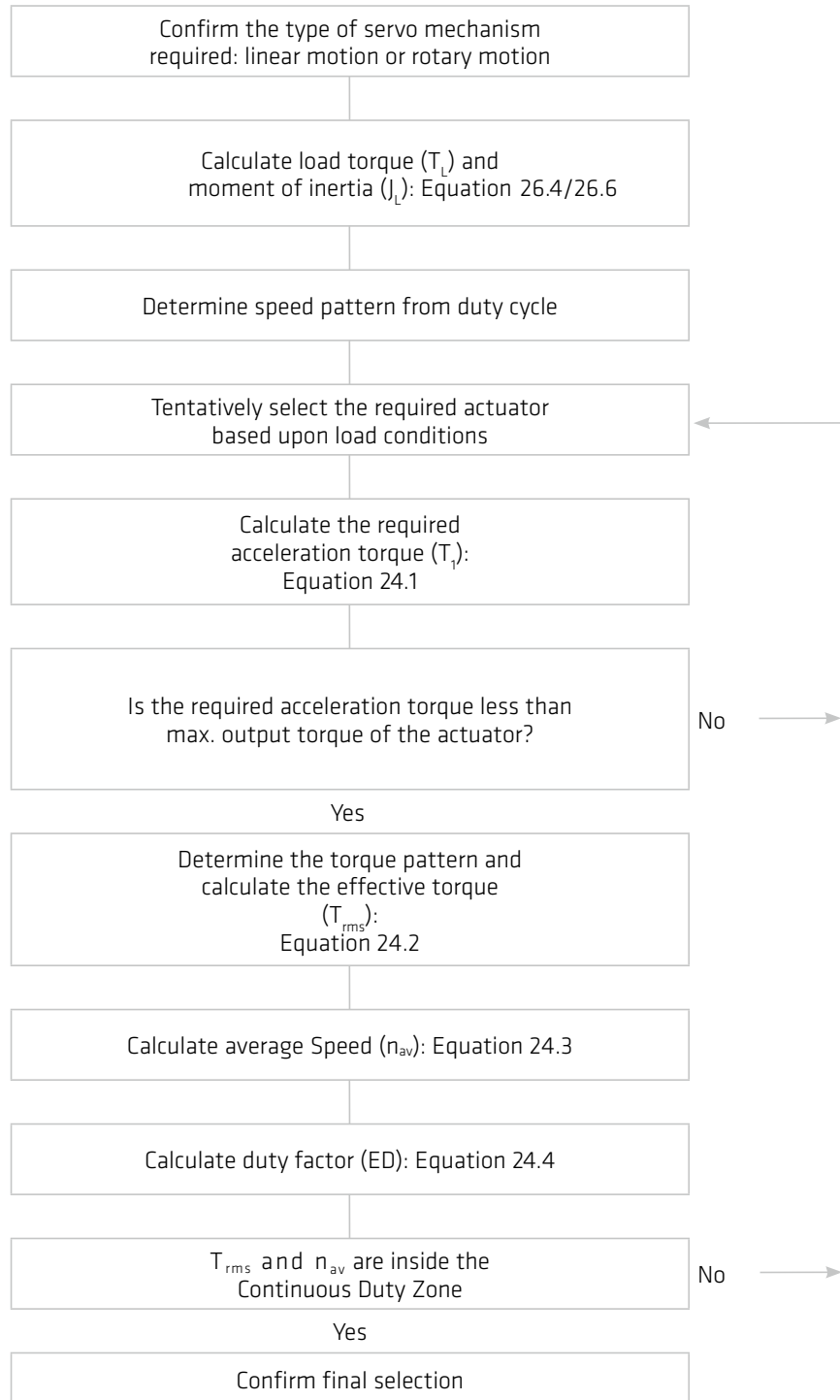

Pre selection conditions

Table 25.1

Load	Confirmation	Catalogue value	Unit
Load max. rotation speed (n_2)	$\leq n_{max}$	Max. output speed	[rpm]
Load moment of inertia (J_L)	$\leq 3J_{Out}^{1)}$	Moment of inertia	[kgm ²]

¹⁾ $J_L \leq 3 \cdot J_{Out}$ is recommended for highly dynamic applications (high responsiveness and accuracy).

Linear horizontal motion

Illustration 25.2

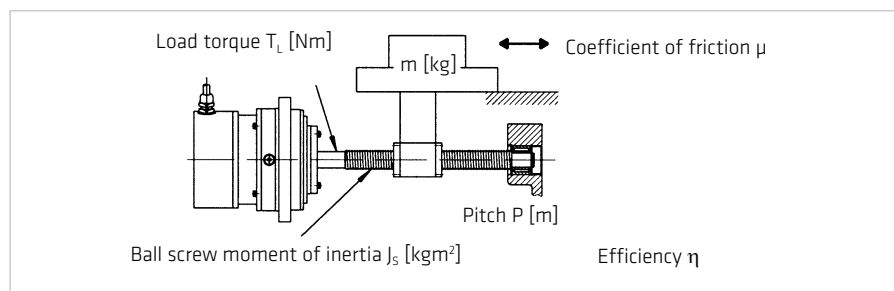

Equation 25.3

$$J_L = J_s + m \left(\frac{P}{2\pi} \right)^2 \text{ [kgm}^2\text{]}$$

$$T_L = \frac{\mu \cdot m \cdot P \cdot g}{2\pi \cdot \eta} \text{ [Nm]}$$

Rotary motion

Illustration 25.4

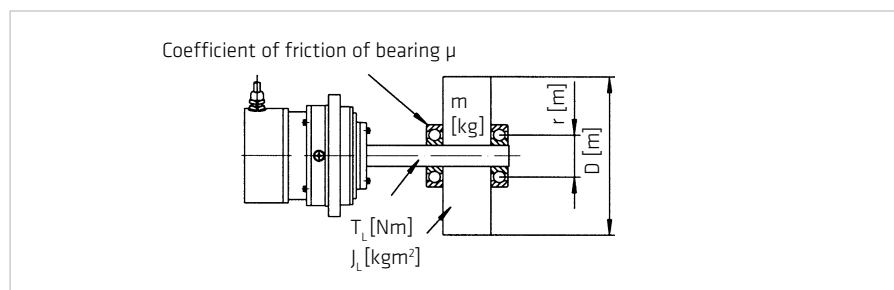

Equation 25.5

$$J_L = \frac{m}{8} \cdot D^2 \text{ [kgm}^2\text{]}$$

$$T_L = \mu \cdot m \cdot g \cdot r \text{ [Nm]} \quad g = 9.81 \text{ [m/s}^2\text{]}$$

Illustration 25.6

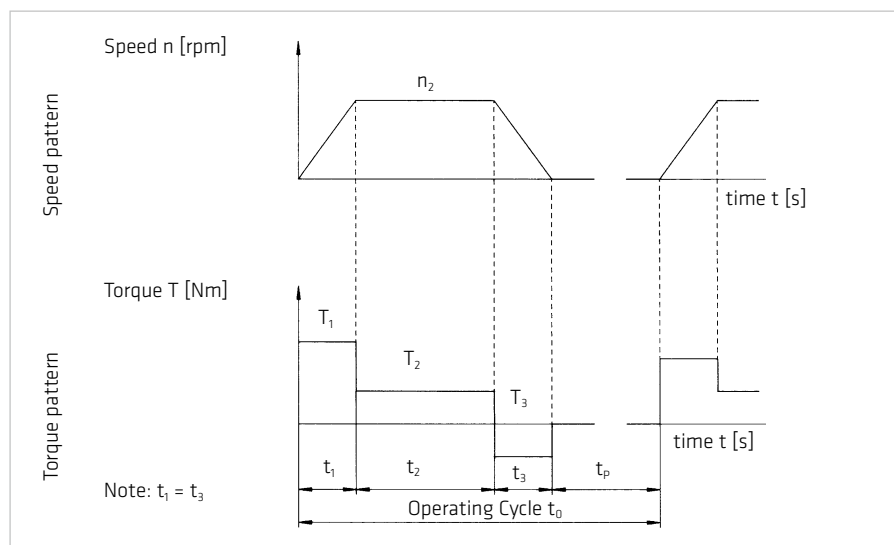

Example of actuator selection

Load Conditions

Assume servo mechanism is used to cyclically position a mass with a horizontal axis of rotation.

Table 26.1

Load rotation speed	$n_2 = 40$ [rpm]
Load torque (e. g. friction)	$T_L = 5$ [Nm]
Load inertia	$J_L = 1.3$ [kgm ²]
Speed pattern	
Acceleration; Deceleration	$t_1 = t_3 = 0.1$ [s]
Operate with rated speed	$t_2 = 0.1$ [s]
Stand still	$t_p = 1$ [s]
Total cycle time	$t_0 = 1.3$ [s]

Please note: Each characteristic value should be converted to the value at the output shaft of the actuator.

Illustration 26.2

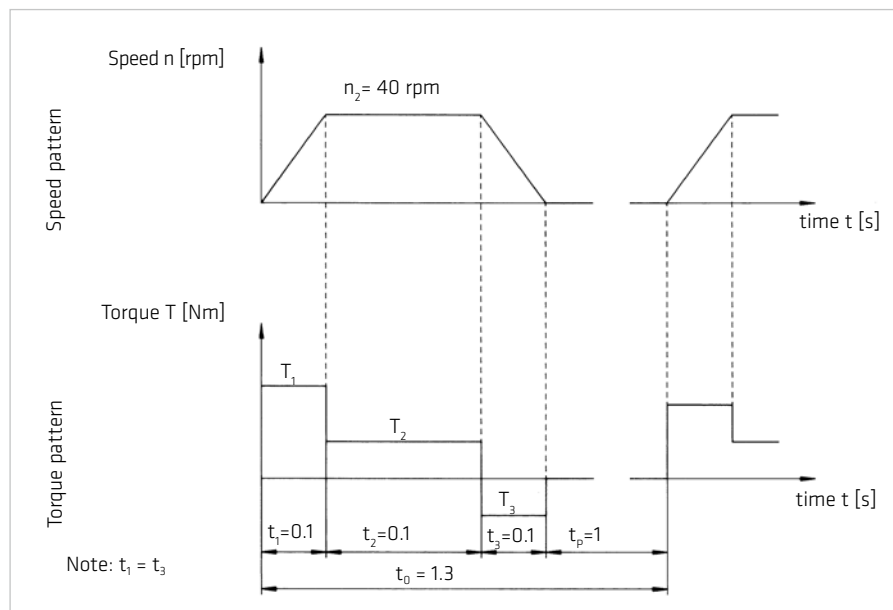

Actuator data FHA-25C-50-L

Table 26.3

Max. Torque	$T_{\max} = 151$ [Nm]
Max. output speed	$n_{\max} = 90$ [rpm]
Moment of inertia	$J_{\text{Out}} = 0.86$ [kgm ²]

Actuator selection

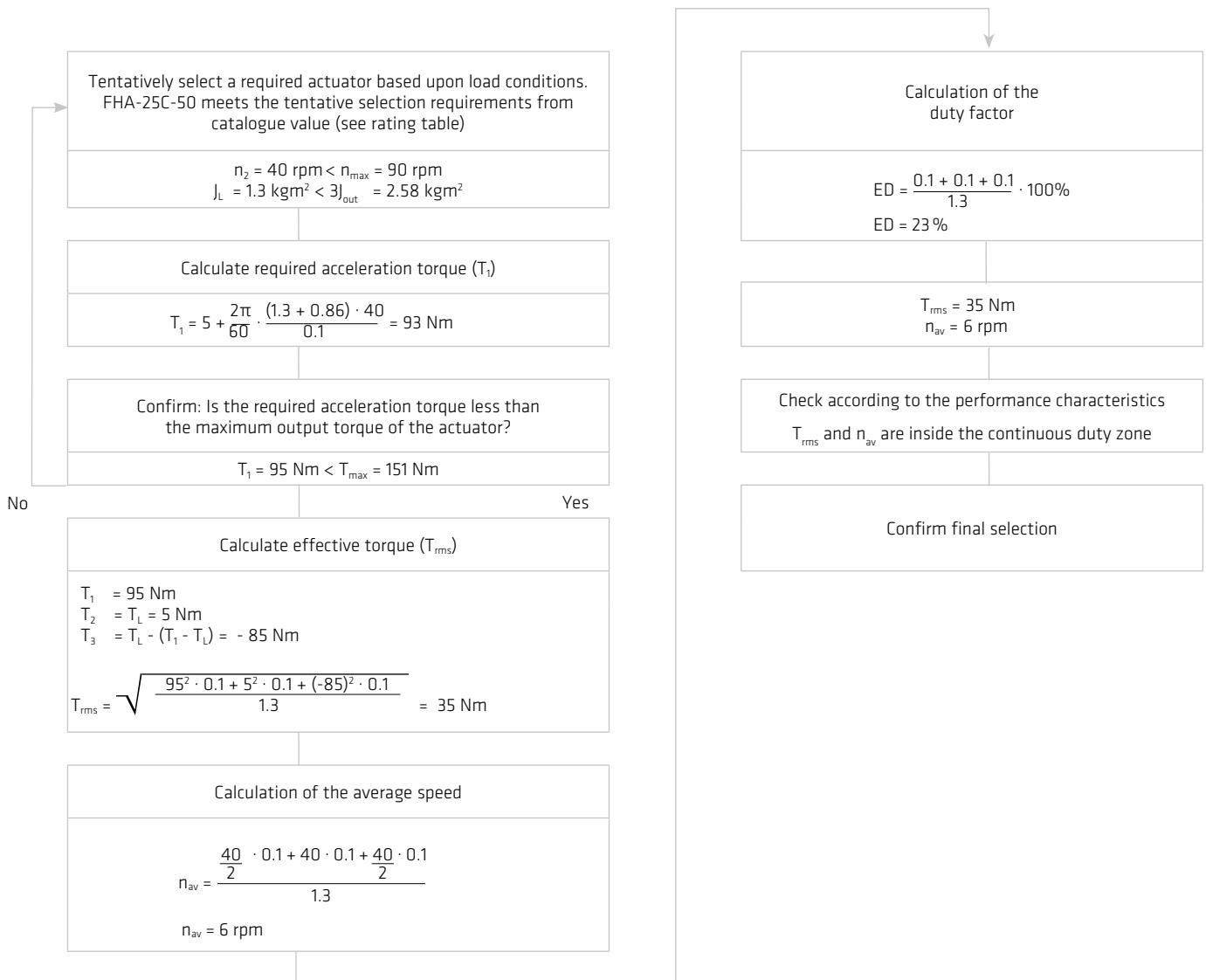
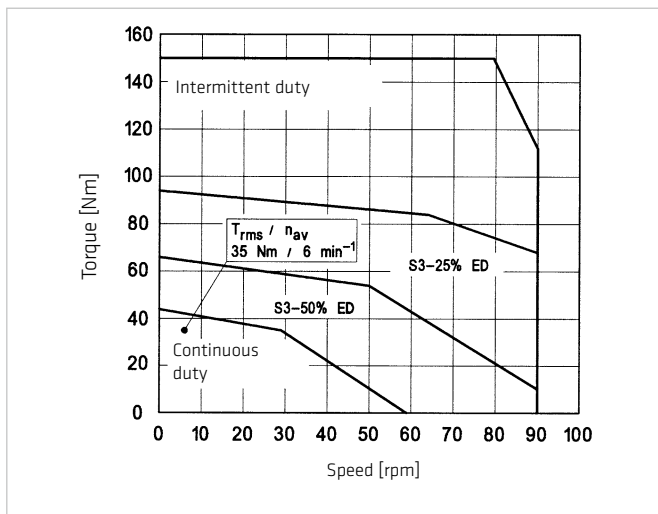

Illustration 271

FHA-25C-50L



$\text{min}^{-1} \triangleq \text{rpm}$

ED = 1min.

ADVICE

We will be pleased to make a gear calculation and selection on your behalf. Please contact our application engineers.

5. Installation and Operation

5.1 Transport and Storage

The transportation of the servo actuators and motors should always be in the original packaging. If the servo actuators and motors are not put into operation immediately after delivery, they should be stored in a dry, dust and vibration-free environment. Storage should be for no longer than 2 years at room temperatures (between +5° C ... +40° C) so that the grease life is preserved.

INFORMATION

Tensile forces in the connecting cable must be avoided.

5.2 Installation

Check the performance and protection and check the suitability of the conditions at the installation site. Take suitable constructive measures to ensure that no liquid (water, drilling emulsion, coolant) can penetrate the output bearing or encoder housing.

ADVICE

The installation must be protected against impact and pressure on the gear.

The mounting must be such that heat loss can be adequately dissipated.

No radial forces and axial forces may act to the protection sleeve of the hollow shaft actuator.

During installation, the actuator must be fitted ensuring the machine housing can be rotated without terminals. Already low terminals may affect the accuracy of the gear and, should this be the case, the installation of the machine housing should be checked.

5.3 Mechanical Installation

The data necessary for mounting the actuator and for connecting to the load are given in table 45.1.

Table 28.1

	Symbol [Unit]	CHM-0083	CHM-0200	CHM-0390	CHM-0800	CHM-1100
Load assembly						
Number of screws		6	6	6	6	6
Screw size		M3	M3	M4	M4	M4
Screw quality		12.9	12.9	12.9	12.9	12.9
Pitch circle diameter	[mm]	27	40	48	53	53
Screw tightening torque	[Nm]	2.3	2.3	5.1	5.1	5.1
Housing assembly						
Number of holes		4 x Ø 7	4 x Ø 11	4 x Ø 13.5	4 x Ø 13.5	4 x Ø 13.5
Screw size		M6	M10	M12	M12	M12
Screw quality		8.8	8.8	8.8	8.8	8.8
Pitch circle diameter	[mm]	130	165	215	215	215
Screw tightening torque	[Nm]	10	48	84.0	84	84

The data in the table are valid for completely cleaned and degreased surfaces (friction coefficient $\mu = 0.15$).

5.4 Electrical Installation

All work should be carried out with power off.



DANGER

Electric servo actuators and motors have dangerous live and rotating parts. All work during connection, operation, repair and disposal must be carried out only by qualified personnel as described in the standards EN50110-1 and IEC 60364! Before starting any work, and especially before opening covers, the actuator must be properly isolated. In addition to the main circuits, the user also has to pay attention to any auxiliary circuits.

Observing the five safety rules:

- Disconnect mains
- Prevent reconnection
- Test for absence of harmful voltages
- Ground and short circuit
- Cover or close off nearby live parts

The measures taken above must only be withdrawn when the work has been completed and the device is fully assembled. Improper handling can cause damage to persons and property. The respective national, local and factory specific regulations must be adhered to.



DANGER

Due to the fact that the motor contains permanent magnets, a voltage is generated at the motor terminals when the rotor is turned.

ADVICE

- The connecting leads should be suitable for the type of use, as well as the voltages and amperages concerned.
- The protective earth must be connected to the terminal marked PE.
- All cables used should be provided with a shield and in addition, the encoder cable should feature twisted pair leads.
- The power supply is switched off before connecting and disconnecting the power connection and signal connections.



ADVICE

Encoders and sensors contain electrostatically sensitive components, observe the ESD measures!

5.5 Commissioning

NOTE

Commissioning must be executed in accordance with the documentation of Harmonic Drive AG.

Before commissioning, please check that:

- The actuator is properly mounted,
- All electrical connections and mechanical connections are designed according to requirements,
- The protective earth is properly connected,
- All attachments (brakes, etc) are operational,
- Appropriate measures have been taken to prevent contact with moving and live parts,
- The maximum speed n_{max} is specified and cannot be exceeded,
- The set up of the drive parameters has been executed,
- The commutation is adjusted correctly.

⚠ ATTENTION

Check the direction of rotation of the load uncoupled.

In the event of changes in the normal operating behaviour, such as increased temperature, noise or vibration, switch the actuator off. Determine the cause of the problem and contact the manufacturer if necessary. Even if the actuator is only on test, do not put safety equipment out of operation.

This list may not be complete. Other checks may also be necessary.

ADVICE

Due to heat generation from the actuator itself, tests outside the final mounting position should be limited to 5 minutes of continuous running at a motor speed of less than 1000 rpm.

These values should not be exceeded in order to avoid thermal damage to the actuator.

5.6 Overload Protection

Temperature sensors are integrated into the servo actuators and motors to protect them from.

To protect the servo actuators and motors from temperature overload sensors are integrated into the motor windings. The temperature sensors alone do not guarantee motor protection. Protection against overload of the motor winding is only possible only with an input speed > 0 . For special applications (eg load at standstill or very low speed) is an additional overload protection by limiting the overload period.

The built specification of the integrated temperature sensors can be found in the technical data.

In addition, it is recommended to protect the motor winding against overload by the use of I^2t monitoring integrated in the controller. The graph shows an example of the overload characteristic for the I^2t monitoring. The overload factor is the ratio between the actual RMS current and continuous stall current.

Illustration 30.1 Over load characteristic

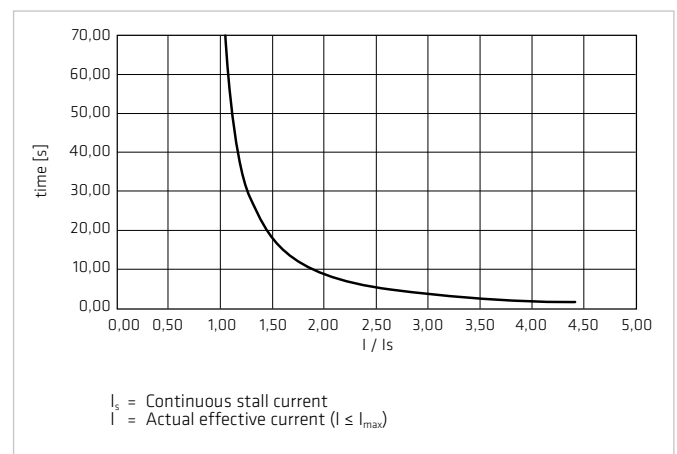

5.7 Protection against Corrosion and Penetration of Liquids and Debris

Table 31.1

	CHM
Corrosion protection	IEC 68 2-11
Salt spray test	Test time 16 h

The product is fully protected provided that the connectors are correctly attached. Corrosion from the ambient atmosphere (condensation, liquids and gases) at the running surface of the output shaft seal is prevented.

Contact between sharp edged or abrasive objects (cutting chips, splinters, metallic or minerals dusts etc) and the output shaft seal must be prevented. Permanent contact between the output shaft seal and a permanent liquid covering should also be prevented.

A change in the operating temperature of a completely sealed actuator can lead to a pressure differential between the outside and the inside temperature of the actuator. This can cause any liquid covering the output shaft seal to be drawn into the housing which could cause corrosive damage.

As a countermeasure, we recommend the use of an additional shaft seal (to be provided by the user) or the maintenance of a constant pressure inside the actuator. Please contact Harmonic Drive AG for further information.

ADVICE

Specification sealing air: constant pressure in the actuator as described above; the supplied air must be dry and filtered with pressure at not more than 10^4 Pa.

5.8 Shutdown and Maintenance

In case of malfunctions or maintenance measures, or to shutdown the motors, proceed as follows:

1. Follow the instructions in the machine documentation.
2. Bring the actuator on the machine to a controlled standstill.
3. Turn off the power and the control voltage on the controller.
4. For motors with a fan unit; turn off the motor protection switch for the fan unit.
5. Turn off the mains switch of the machine.
6. Secure the machine against accidental movement and against unauthorised operation.
7. Wait for the discharge of electrical systems then disconnect all the electrical connections.
8. Secure the motor, and possibly the fan unit, before disassembly against falling or movement then pay attention to the mechanical connections.

DANGER

Risk of death by electric voltages. Work in the area of live parts is extremely dangerous.

- Work on the electrical system may only be performed by qualified electricians. The use of a power tool is absolutely necessary.

Observing the five safety rules:

- Disconnect mains
- Prevent reconnection
- Test for absence of harmful voltages
- Ground and short circuit
- Cover or close off nearby live parts

The measures taken above must only be withdrawn when the work has been completed and the device is fully assembled. Improper handling can cause damage to persons and property. The respective national, local and factory specific regulations must be adhered to.

ATTENTION

Burns from hot surfaces with temperatures of over 100° C

Let the motors cool down before starting work. Cooling times of up to 140 minutes may be necessary. Wear protective gloves. Do not work on hot surfaces!

WARNING

Persons and property during maintenance and operation

Never perform maintenance work on running machinery. Secure the system during maintenance against re-starting and unauthorised operation.

Cleaning

Excessive dirt, dust or chips may adversely affect the operation of the device and can, in extreme cases, lead to failure. At regular intervals you should therefore, clean the device to ensure a sufficient dissipation of the surface heat. Insufficient heat emissions can have undesirable consequences. The lifetime of the device is reduced if temperature overloads occurs. Overtemperature can lead to the shutdown of the device.

Checking of electric connections



Lethal electric shock by touching live parts!

In any case of defects of the cable sheath the system must be shut down immediately and the damaged cable should be replaced. Do not make any temporary repairs on the connection cables.

- Connection cord should be periodically checked for damage and replaced if necessary.
- Check optionally installed power chains (power chains) for defects.
- Protective conductor connections should be in a good condition and tightness checked at regular intervals. Replace if necessary.

Control of mechanical fasteners

The fastening screws and the load of the housing must be checked regularly.

6. Decommissioning and Disposal

The servo actuators and motors from Harmonic Drive AG include lubricants, electronic components and printed circuit boards.

Since lubricants (greases and oils) are considered hazardous substances in accordance with health and safety regulations, it is necessary to dispose of the products correctly. Please ask for safety data sheet where necessary.

7. Glossary

7.1 Technical Data

AC Voltage constant k_{EM} [$V_{rms} / 1000 \text{ rpm}$]

Effective value of the induced motor voltage measured at the motor terminals at a speed of 1000 rpm and an operating temperature of 20° C.

Ambient operating temperature [$^{\circ}\text{C}$]

The intended operating temperature for the operation of the drive.

Average input speed (grease lubrication) $n_{av(max)}$ [rpm]

Maximum permissible average gear input speed for grease lubrication.

Average input speed (oil lubrication) $n_{av(max)}$ [rpm]

Maximum permissible average gear input speed for oil lubrication.

Average torque T_A [Nm]

When a variable load is applied to the gear, an average torque should be calculated for the complete operating cycle. This value should not exceed the specified T_A limit.

Backlash (Harmonic Planetary gears) [arcmin]

When subjected to the rated torque, Harmonic Planetary gears display characteristics shown in the hysteresis curve. When a torque is applied to the output shaft of the gear with the input shaft locked, the torque-torsion relationship can be measured at the output. Starting from point O the graph follows successive points A-B-A-B-A where the value B-B is defined as the backlash or hysteresis.

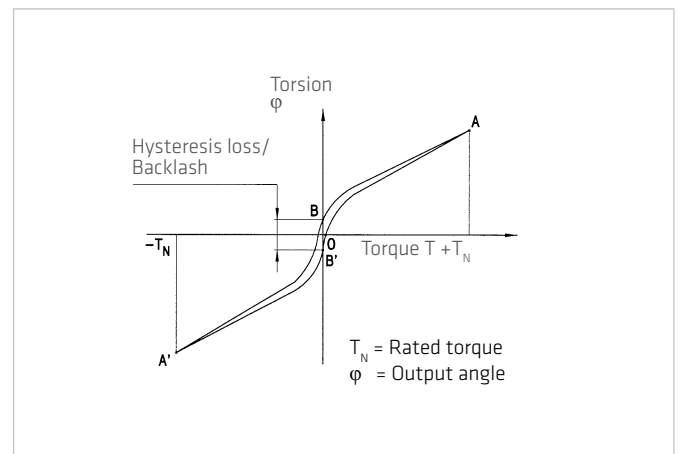

Brake closing time t_c [ms]

Delay time to close the brake.

Brake current to hold I_{HBr} [A_{DC}]

Current for applying the brake.

Brake current to open I_{OBr} [A_{DC}]

Current required to open the brake.

Brake holding torque T_H [Nm]

Torque the actuator can withstand when the brake is applied, with respect to the output.

Brake opening time t_o [ms]

Delay time for opening the brake.

Brake voltage U_{Br} [VDC]

Terminal voltage of the holding brake.

Continuous stall current I_0 [A_{rms}]

Effective value of the motor phase current to produce the stall torque.

Continuous stall torque T_0 [Nm]

Allowable actuator stall torque.

Demagnetisation current I_E [A_{rms}]

Current at which rotor magnets start to demagnetise.

Dynamic axial load $F_{A\ dyn\ (max)}$ [N]

With bearing rotating this is the maximum allowable axial load, with no additional radial forces or tilting moments applied.

Dynamic load rating C [N]

Maximum dynamic load that can be absorbed by the output bearing before permanent damage may occur.

Dynamic radial load $F_{R\ dyn\ (max)}$ [N]

With bearing rotating this is the maximum allowable radial load, with no additional axial forces or tilting moments applied.

Dynamic tilting moment $M_{dyn\ (max)}$ [Nm]

With the bearing rotating this is the maximum allowable tilting moment, with no additional axial forces or radial forces applied.

Electrical time constant τ_e [s]

The electrical time constant is the time required for the current to reach 63% of its final value.

Hollow shaft diameter d_H [mm]

Free inner diameter of the continuous axial hollow shaft.

Inductance (L-L) L_{L-L} [mH]

Terminal inductance calculated without taking into account the magnetic saturation of the active motor parts.

Lost Motion (Harmonic Drive® Gearing) [arcmin]

Harmonic Drive® Gearing exhibits zero backlash in the teeth. Lost motion is the term used to characterise the torsional stiffness in the low torque region.

The illustration shows the angle of rotation ϕ measured against the applied output torque as a hysteresis curve, with the Wave Generator locked. The lost motion measurement of the gear is taken with an output torque of about $\pm 4\%$ of the rated torque.

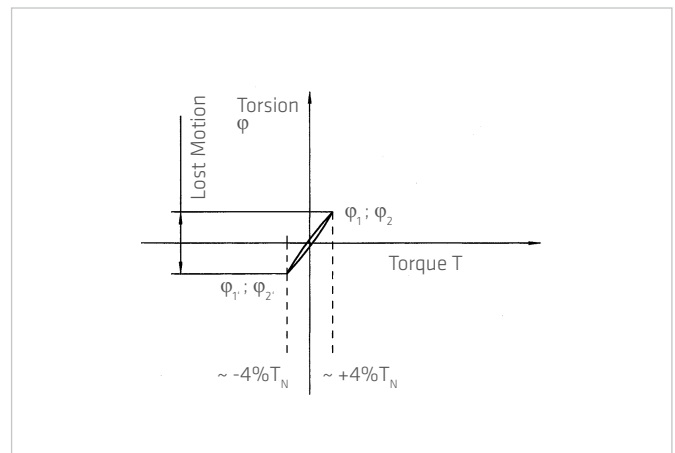

Maximum current I_{max} [A]

The maximum current is the maximum current that can be applied for a short period.

Maximum DC bus voltage $U_{DC(max)}$ [VDC]

The maximum DC bus power supply for the correct operation of the actuator. This value may only be exceeded for a short period during the braking or deceleration phase.

Maximum hollow shaft diameter $d_{H(max)}$ [mm]

For gears with a hollow shaft, this value is the maximum diameter of the axial hollow shaft.

Maximum input speed (grease lubrication) $n_{in(max)}$ [rpm]

Maximum allowed input speed for gearing with grease lubrication.

Maximum input speed (oil lubrication) $n_{in(max)}$ [rpm]

Maximum allowed input speed for gearing with oil lubrication.

Maximum motor speed n_{max} [rpm]

The maximum allowable motor speed.

Maximum output speed n_{max} [rpm]

The maximum output speed. Due to heating issues, this may only be momentarily applied during the operating cycle. The maximum output speed can occur any number of times as long as the rated speed is greater than the permissible continuous operation calculated in the duty cycle.

Maximum output torque T_{max} [Nm]

Specifies the maximum allowable acceleration and deceleration torques. For highly dynamic processes, this is the maximum torque available for a short period. The maximum torque can be parameterized by the control unit where the maximum current can be limited. The maximum torque can be applied as often as desired, as long as the average torque is within the permissible continuous operation calculated in the duty cycle.

Maximum power P_{max} [W]

Maximum power output.

Mechanical time constant τ_m [s]

The mechanical time constant is the time required to reach 63% of its maximum rated speed in a no-load condition.

Momentary peak torque T_M [Nm]

In the event of an emergency stop or collision, the Harmonic Drive® Gearing may be subjected to a brief collision torque. The magnitude and frequency of this collision torque should be kept to a minimum and under no circumstances should the momentary peak torque occur during the normal operating cycle.

Moment of inertia J [kgm²]

Mass moment of inertia at motor side.

Moment of inertia J_{in} [kgm²]

Mass moment of inertia of the gearing with respect to the input.

Moment of inertia J_{out} [kgm²]

Mass moment of inertia with respect to the output.

Motor terminal voltage (Fundamental wave only) $U_M [V_{rms}]$

Required fundamental wave voltage to achieve the specified performance. Additional power losses can lead to restriction of the maximum achievable speed.

Number of pole pairs p

Number of magnetic pole pairs on the rotor of the motor.

Offset $R [mm]$

Distance between output bearing and contact point of load.

Pitch circle diameter $d_p [mm]$

Pitch circle diameter of the output bearing.

Protection IP

The degree of protection according to EN 60034-5 provides suitability for various environmental conditions.

Rated current $I_N [A]$

Rms value of the sinusoidal current when driven at rated torque and rated speed.

Rated motor speed $n_N [rpm]$

The motor speed which can be continuously maintained when driven at rated torque T_N , when mounted on a suitably dimensioned heat sink.

Rated power $P_N [W]$

Output power at rated speed and rated torque.

Rated speed $n_N [rpm]$

The output speed which can be continuously maintained when driven at rated torque T_N , when mounted on a suitably dimensioned heat sink.

Rated torque $T_N [Nm]$, Servo

The output torque which can be continuously transmitted when driven at rated input speed, when mounted on a suitably dimensioned heat sink.

Rated torque $T_N [Nm]$, Mechanic

The rated torque is a reference torque for the calculation of the gear life. When loaded with the rated torque and running at rated speed the gear will reach the average life L_{50} . The rated torque T_N is not used for the dimensioning of the gear.

Rated voltage $U_N [V_{rms}]$

Supply voltage for operation with rated torque and rated speed.

Ratio $i []$

The ratio is the reduction of input speed to the output speed.

Note for Harmonic Drive® transmission: The standard version of the wave is generating the drive element, the output element of the flexspline and the circular Spline is fixed to the housing. Since the direction of rotation of the drive (Wave Generator) to output reverses (Flexspline), a negative ratio for results Calculations in which the direction of rotation must be considered.

Repeatability [arcmin]

The repeatability of the gear describes the position difference measured during repeated movement to the same desired position from the same direction. The repeatability is defined as half the value of the maximum difference measured, preceded by a \pm sign.

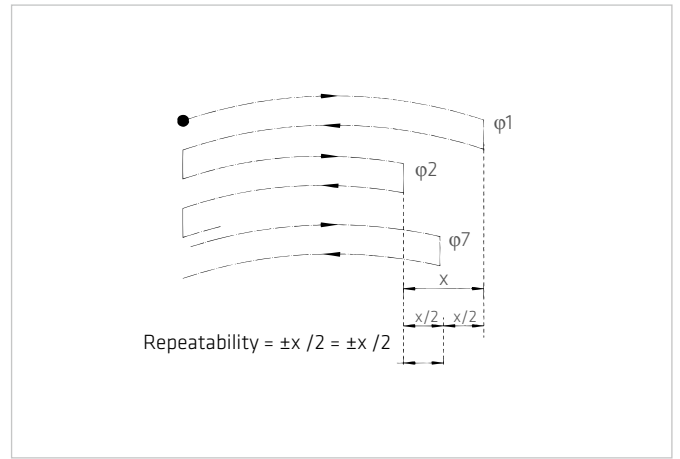

Repeated peak torque T_R [Nm]

Specifies the maximum allowable acceleration and braking torques. During the normal operating cycle the repeated peak torque T_R should not be exceeded.

Resistance (L-L, 20° C) R_{L-L} [Ω]

Winding resistance measured between two conductors at a winding temperature of 20° C.

Size

1) Actuators / Gears with Harmonic Drive® gears or Harmonic Planetary gears

The frame size is derived from the pitch circle diameter of the gear teeth in inches multiplied by 10.

2) CHM Servo motor series

The size of the CHM servo motors is derived from the stall torque in Ncm.

3) Direct drives from the TorkDrive® series

The size of the TorkDrive® series is the outer diameter of theiron core of the stator.

Static load rating C_0 [N]

Maximum static load that can be absorbed by the output bearing before permanent damage may occur.

Static tilting moment M_0 [Nm]

With the bearing stationary this is the maximum allowable radial load, with no additional axial forces or tilting moments applied.

Tilting moment stiffness K_b [Nm/arcmin]

The tilting angle of the output bearing at an applied moment load.

Torque constant (motor) k_{TM} [Nm/A_{rms}]

Quotient of stall torque and stall current.

Torque constant (output) k_{Tout} [Nm/A_{rms}]

Quotient of stall torque and stall current, taking into account the transmission losses.

Torsional stiffness (Harmonic Drive® Gears) K_3 [Nm/rad]

The amount of elastic rotation at the output for a given torque and the Wave Generator blocked. The torsional stiffness K_3 describes the stiffness above a defined reference torque where the stiffness is almost linear. Values below this torque can be requested or found on our web site.

The value given for the torsional stiffness K_3 is an average that has been determined during numerous tests. The limit torques T_1 and T_2 and calculation example for the total torsional angle Gesamtverdrehwinkels can be found in the secondary technical documentation.

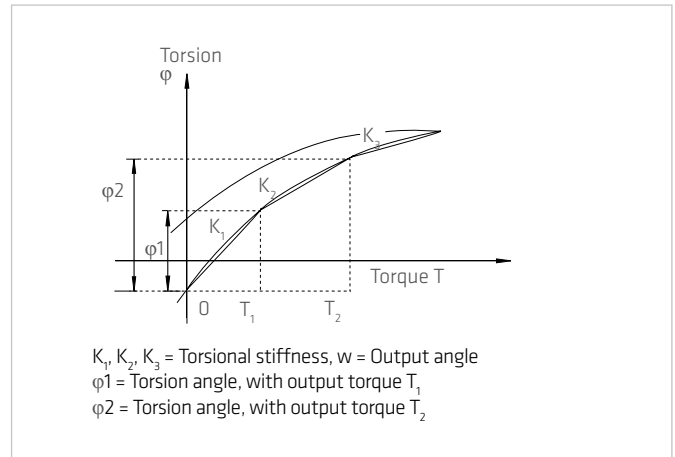

Torsional stiffness (Harmonic Planetary gears) K [Nm/rad]

The amount of elastic rotation at the output for a given torque and blocked input shaft. The torsional rigidity of the Harmonic Planetary gear describes the rotation of the gear above a reference torque of 15% of the rated torque. In this area the torsional stiffness is almost linear.

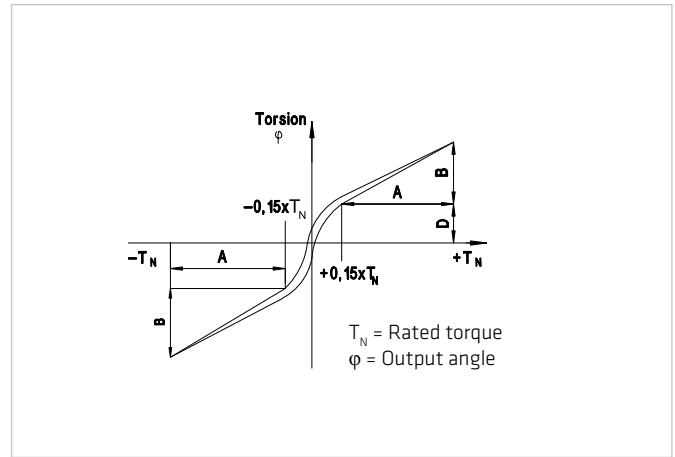

Transmission accuracy [arcmin]

The transmission accuracy of the gear represents a linearity error between input and output angle. The transmission accuracy is measured for one complete output revolution using a high resolution measurement system. The measurements are carried out without direction reversal. The transmission accuracy is defined as the sum of the maximum positive and negative differences between theoretical and actual output rotation angle.

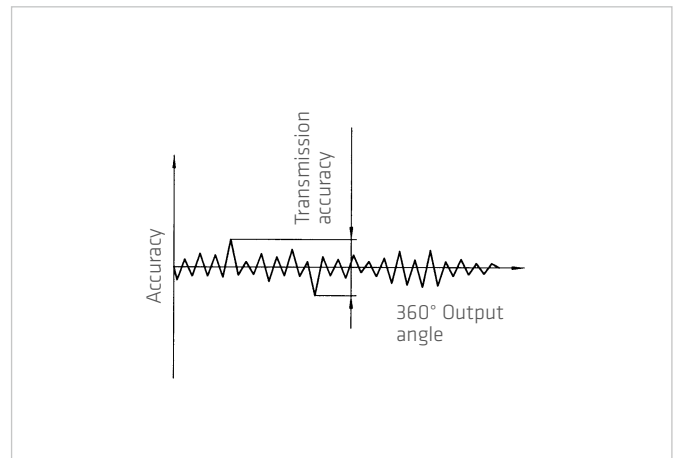

Weight m [kg]

The weight specified in the catalog is the net weight without packing and only applies to standard versions.

7.2 Labelling, Guidelines and Regulations

CE-Marking

With the CE marking, the manufacturer or EU importer declares in accordance with EU regulation, that by affixing the CE mark the product meets the applicable requirements in the harmonization legislation established the Community.



REACH Regulation

REACH is a European Community Regulation on chemicals. REACH stands for Registration, Evaluation, Authorization and Restriction of Chemicals.





RoHS EU Directive

The RoHS EU Directive on the restriction of the use of certain hazardous substances in electrical and electronic equipment.



8. Appendix

8.1 Declaration of Conformity

EG-Konformitätserklärung EC Declaration of Conformity		 Harmonic Drive AG
Hersteller, Manufacturer:	Harmonic Drive AG	
Anschrift, Address	Hoenbergstraße 14 65555 Limburg	
Produktbezeichnung:	Servoantrieb CHA-20A~58A (in Standardbauform)	
Product description:	Servomotor CHM-0083A~1100A (in Standardbauform) Servo Actuator CHA-20A~58A (standard version) Servo Motor CHM-0083A~1100A (standard version)	
<p>Die oben bezeichneten Produkte stimmen in der von uns in Verkehr gebrachten Ausführung mit den Vorschriften folgender Europäischer Richtlinien überein. <i>The products described above in the form as delivered are in conformity with the provisions of the following European Directives.</i></p>		
2014/35/EG	Elektrische Betriebsmittel zur Verwendung innerhalb bestimmter Spannungsgrenzen.	
2014/35/EC	<i>Electrical equipment designed for use within certain voltage limits.</i>	
<p>Die Konformität wird nachgewiesen durch die Einhaltung nachfolgender Normen. <i>Conformity is assured through the application of the following Standards.</i></p> <ul style="list-style-type: none">• EN 60034-1/ 2010• EN 61800-5-1/ 2008• EN 60664-1/ 2008		
2004/108/EG	Elektromagnetische Verträglichkeit.	
2004/108/EC	<i>Electromagnetic compatibility.</i>	
<p>Die Konformität wird nachgewiesen durch die nachfolgender Normen. <i>Conformity is assured through the application of the following Standards.</i></p> <ul style="list-style-type: none">• EN 61800-3/ 2012		
<p>Die Sicherheitshinweise und die technischen Dokumentation sind zu beachten. <i>The safety requirements and the technical documentation have to be considered.</i></p>		
CE-Kennzeichnung/ CE marking:		January 2006
Limburg, 01.08.2014		
		
i. V. Ralf Falk		i. A. Alois Buss
Leiter Konstruktion und Entwicklung Servotechnik		Produktmanager Servotechnik
Section Manager Design and Development Servo Drives		Product Manager Servo Drives

Rev.: 06/12

...just move it!



Deutschland
Harmonic Drive AG
Hoenbergstraße 14
65555 Limburg/Lahn

T +49 6431 5008-0
F +49 6431 5008-119

info@harmonicdrive.de
www.harmonicdrive.de



Subject to technical changes